

**STANDARD FEATURES**

- \*Stainless Steel front and sides are standard
- \*6" adjustable chrome steel legs
- \*Type 304 Stainless Steel frypot standard
- \*Two chrome plated fry baskets
- \*1/2" NPT gas connection
- \*1 1/4" drain valve
- \*Large cool zone isolates food particle from the frying area. This prevents food particles from carbonizing, prolonging the life of the oil.
- \*Snap acting mechanical thermostat 200F to 400F
- \*Millivolt pilot requires no electrical connection
- \*Automatic single standing pilot ignition
- \*100% safety shutoff
- \*Sloped tank bottom to allow oil to fully drain
- \*Clean-out rod
- \*Range Match
- \*Crumb Screen
- \*Drain Tube
- \*One year limited parts and labor warranty

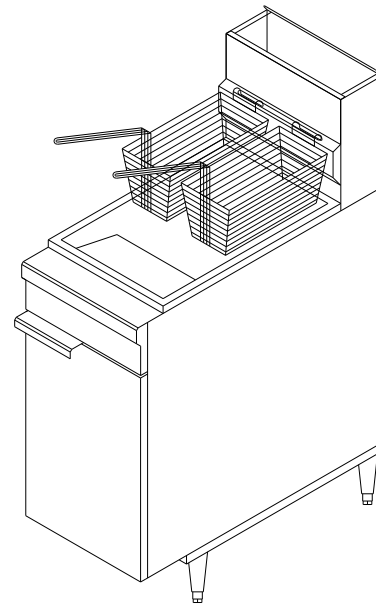

**TF25 - 25lb Fryer**  
**TF2525 - 50lb Split Fryer**  
**TF40 - 40lb Fryer (shown)**  
**TF50 - 50lb Fryer**  
**TF75 - 75lb Fryer**

**OPTIONAL FEATURES**

- \*Trim kits for multiple connections
- \*Gas flex hose w/quick disconnect and restraining devise
- \*Set of 4 swivel casters with front brakes
- \*Stainless Steel frypot cover

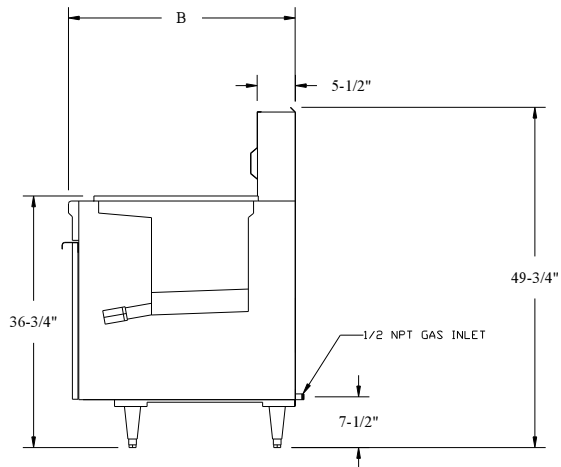
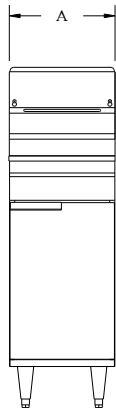

**GAS REQUIREMENTS**

- \*Manifold pressure
  - \*4.0" WC Natural Gas (NAT)
  - \*10.0" WC Propane Gas (LP)
  - \*When ordering please specify Natural or Propane Gas
- \*Manifold 1/2" NPT
- \*Input rating per burner
  - \*Fryer burner: 35,000 BTU/Hr

**GAS CONSUMPTION**

Model No.	Total BTU's	Burners	"A"	"B"
TF25 - 25lb fryer	55,000	2	7-3/4"	33-1/8"
TF2525 - 50lb fryer	110,000	4	15-1/2"	33-1/8"
TF40 - 40lb fryer	105,000	3	15-1/2"	33-1/8"
TF50- 50lb fryer	140,000	4	15-1/2"	33-1/8"
TF75 - 75lb fryer	175,000	5	19-1/2"	37-3/8"

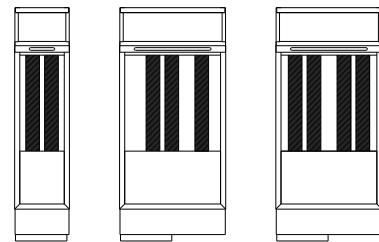

TF25      TF40      TF50

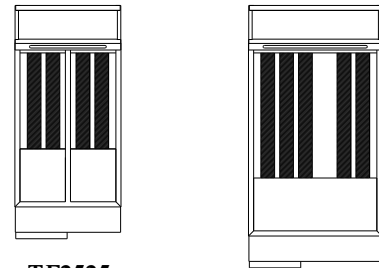

TF2525      TF75

**ELECTRICAL REQUIREMENTS**

- \* Millivolt Pilot System:
  - \* No electrical connection required.

**CLEARANCES**

	Sides	Back
*Non Combustible	0"	0"
*Combustible	6"	6"



**WARRANTY**

All THERMA-TEK Commercial Fryers are covered by a one year limited parts and labor warranty. A detailed warranty is included with the appliance or is available upon request.

\* 4 Years Tank Warranty