

## STANDARD FEATURES

- \*All stainless steel exterior, interior surfaces are constructed of a corrosion resistant aluminized steel.
- \*Four adjustable rack positions.
- \*One nickel plated shelf sized to model width.
- \*Available in 24", 36", 48", 60", and 72" widths. Larger optional sizes available.
- \*Rapid fire ceramic infra-red tile burners: 20,000 BTU's/hr or 35,000 BTU's/hr or combination of the two depending upon model widths.
- \*Each burner is individually controlled.
- \*Each burner has a standing pilot ignition system.
- \*Drip pan is easily removable for cleaning.
- \*Standing pilot ignition system.
- \*Available for counter, wall and range mount.
- \*"4" Adjustable legs. (counter model)
- \*Gas pressure regulator
- \*One year limited parts and labor warranty.

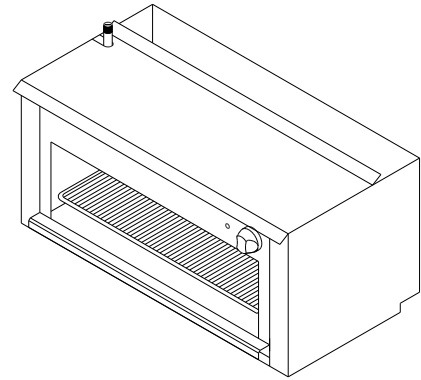

MODEL # TCM36 (shown)

## OPTIONAL FEATURES

- \*Wall mount kits
- \*Counter mount kits
- \*Range mount kits
- \*Extra wire racks

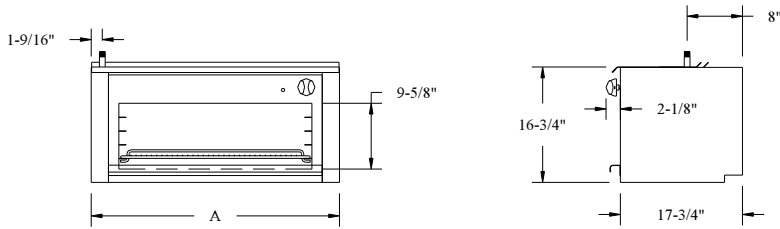

**GAS REQUIREMENTS**

- \*Manifold pressure
  - \* 5.0" WC Natural Gas (NAT)
  - \* 10.0" WC Propane Gas (LP)
  - \* When ordering please specify Natural or Propane Gas
- \*Manifold 1/2" NPT
- \*Input rating per burner
  - \* Infra-red burner: 20,000 BTU/Hr or 35,000 BTU/Hr (depending on model)

*TOTAL GAS CONSUMPTION PER MODEL	A	Burners	Total Input BTU/HR.
*TCM24	24"	1	20,000
*TCM36	36"	1	35,000
*TCM48	48"	2	40,000
*TCM60	60"	2	55,000
*TCM72	72"	2	70,000

**CLEARANCES      Sides      Back**

- \*Non Combustible      0"      0"
- \*Combustible      6"      6"



**WARRANTY**  
All THERMA-TEK Counter Series are covered by a one year limited parts and labor warranty. A detailed warranty is included with the appliance or is available upon request

